

ITEM NO.	PART NUMBER	DIMENSION	QTY.	Material	Weight	SUR.H	REMARKS
1	16.NECK	AS SHOW	1	AISI 4140	6 Kg	22 HRC	PROCESS CASTING

√ (3.2/)

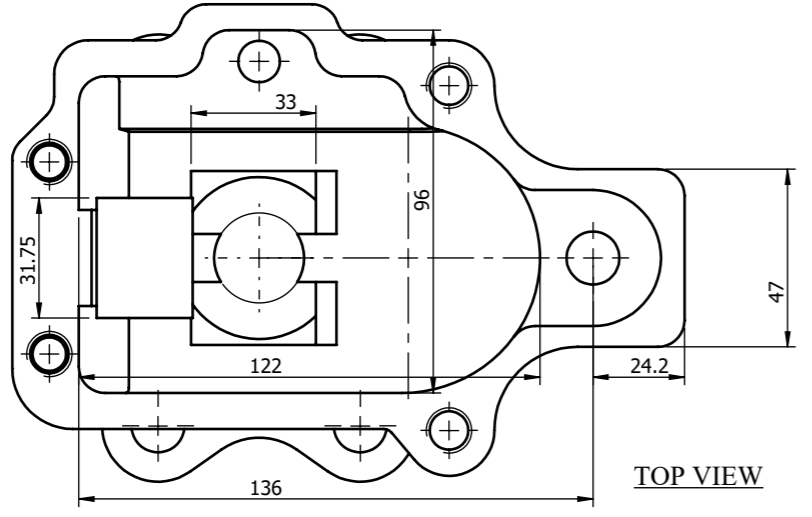
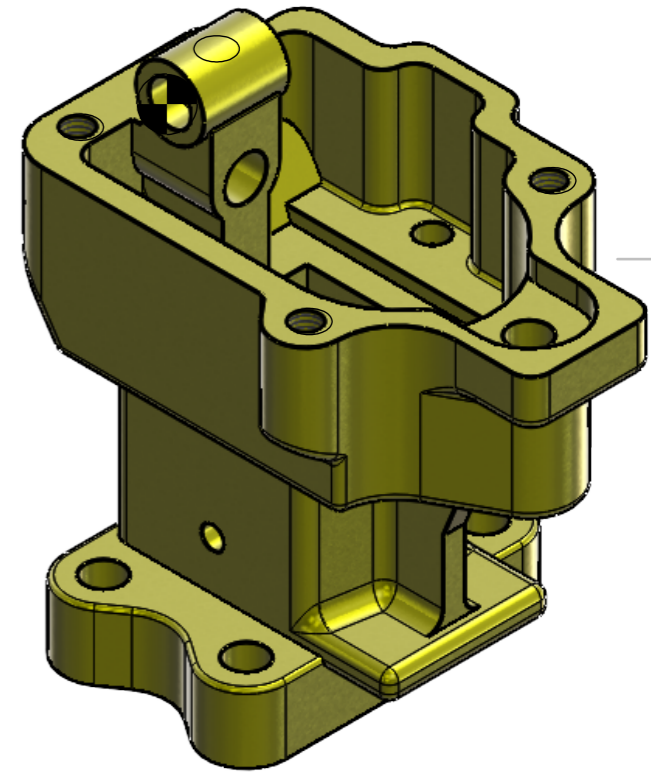
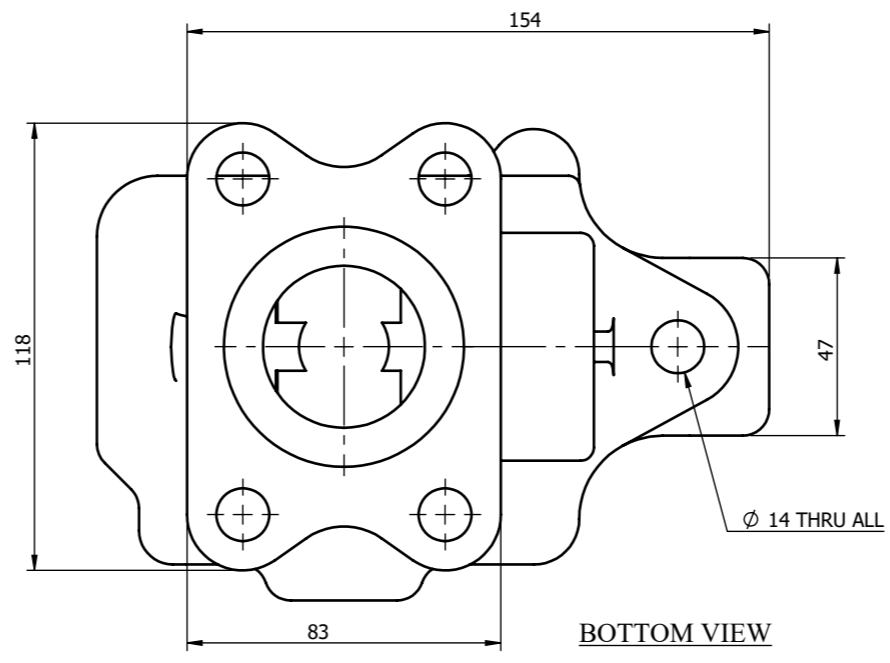
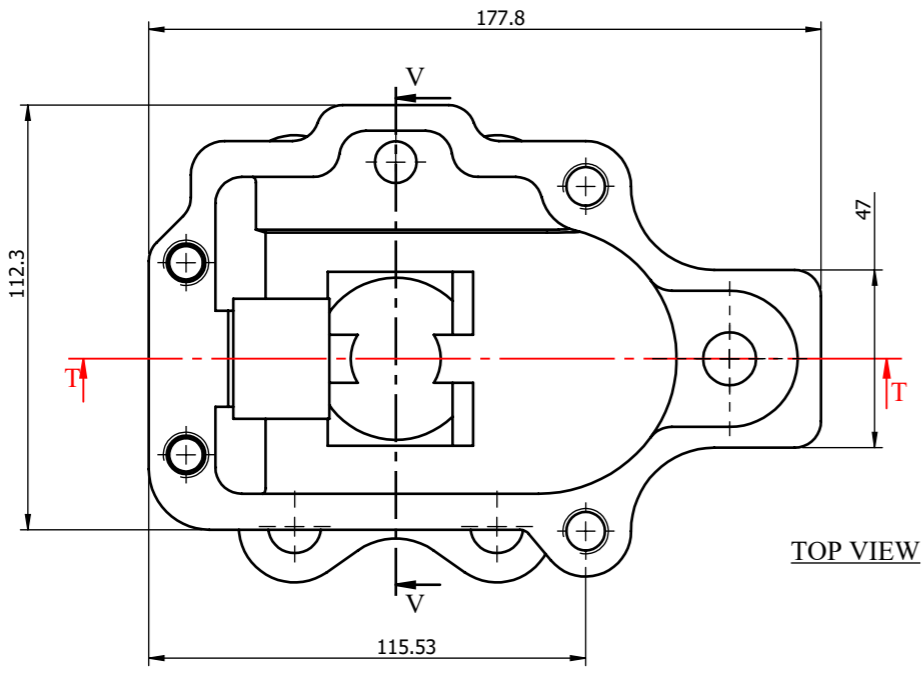
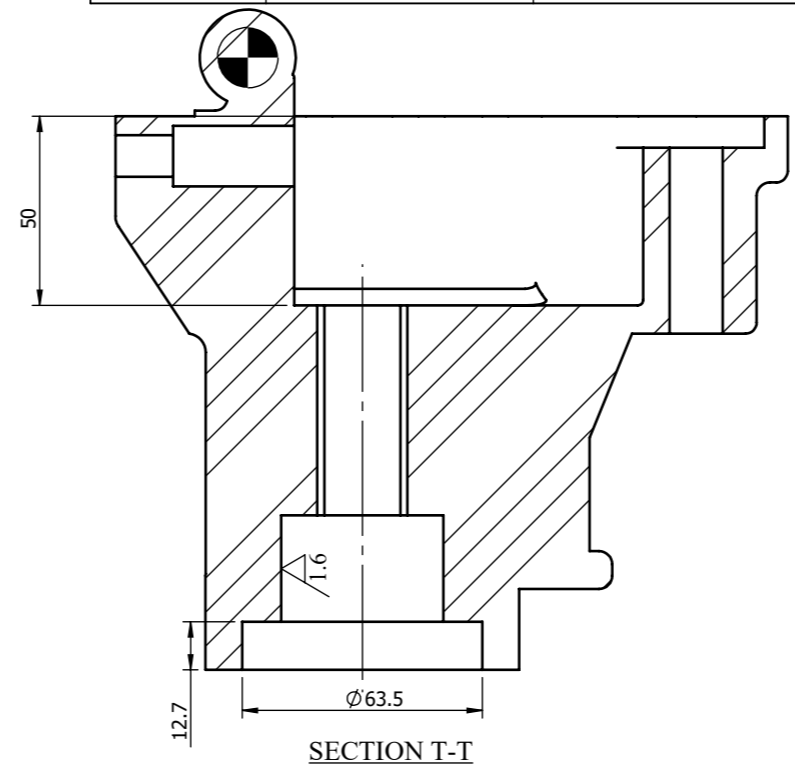
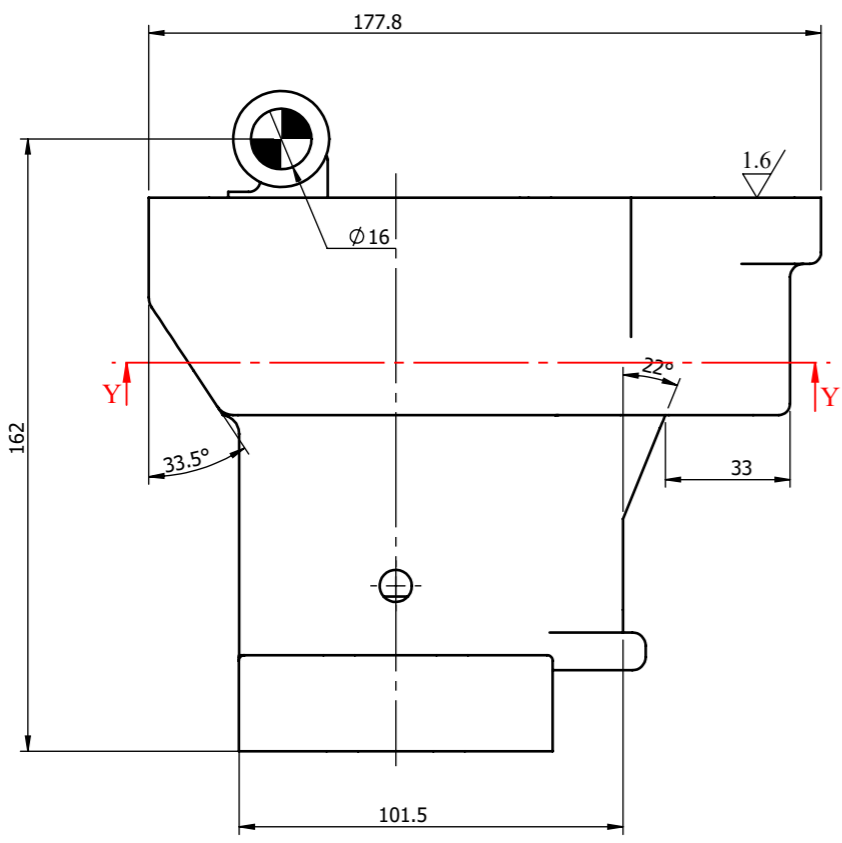

NOTE2: Remove All sharp Edges.
NOTE1: Unspecified tolerances is according to ISO 2768M.

REV	DATE	NAME	SIGN	SCALE	TITLE
0	1405/02/01	J.Motedayen		1:1	VALVE ASSY. 3".1500-5000 PSI
SKETCH	1405/02/01	J.Motedayen			M.E.S.C NO: -----
DRAWN	1405/02/01	J.Motedayen			PART NO: -----
CHECKED	1405/02/01	J.Motedayen			SHEET: 1 OF 9
APPROVED	1405/02/01	MR.SHEBANI			DWG NO: SH-P01.716-13