

ITEM NO.	PART NUMBER	DIMENSION	QTY.	Material	Weight	SUR.H	COR.H	REMARKS
24	24.STEEL ARM	AS SHOWN	1	AISI 4140	1 Kg	----	----	CASTING

✓ (3.2/)

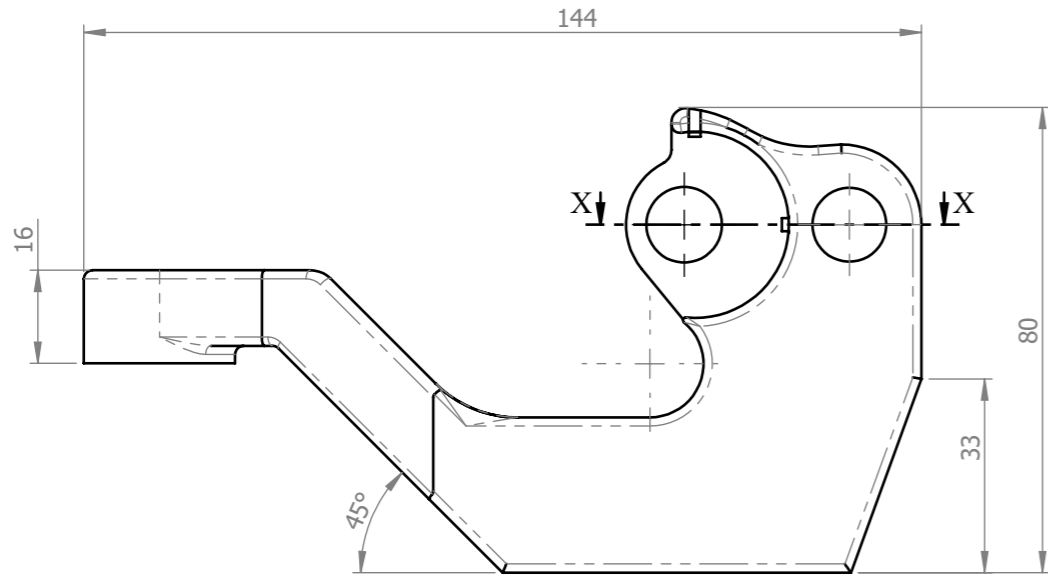

FRONT VIEW

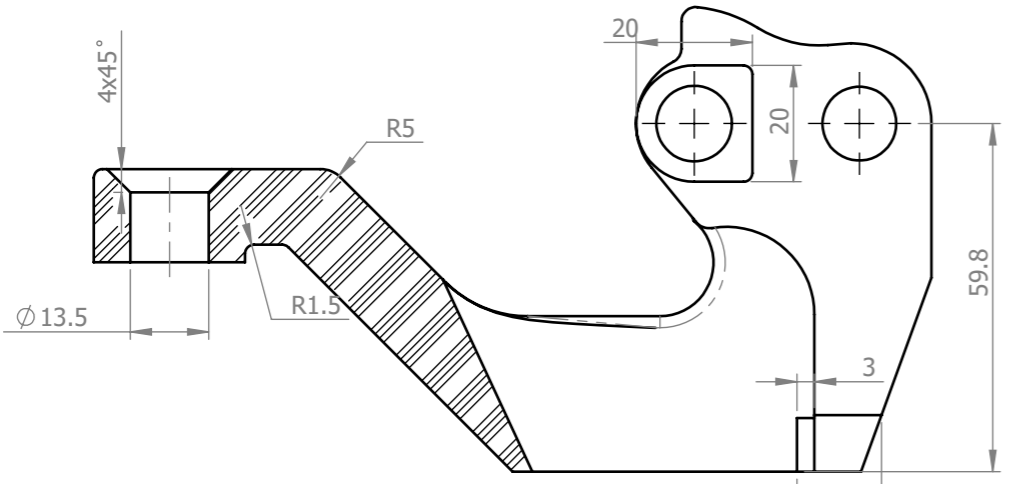
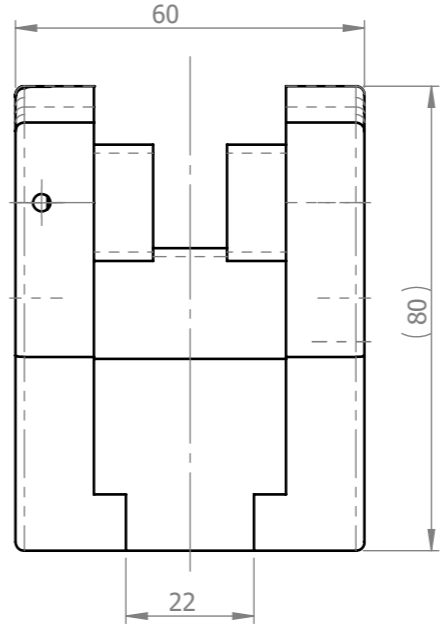

SECTION A-A
SCALE 1 : 1.3

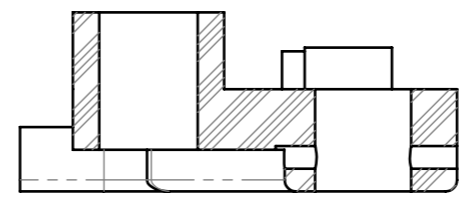
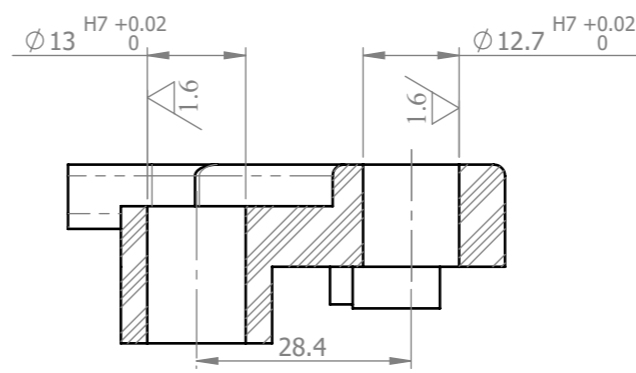

SECTION X-X

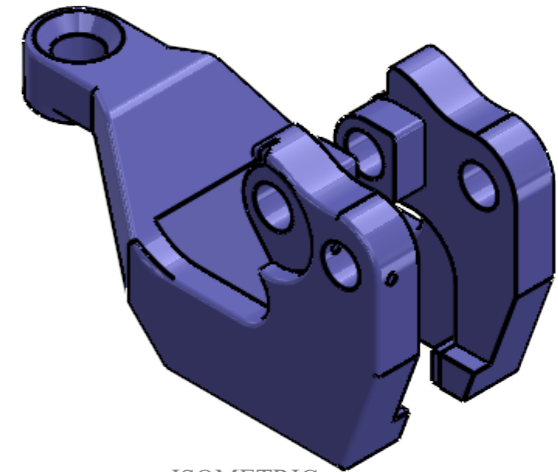

ISOMETRIC

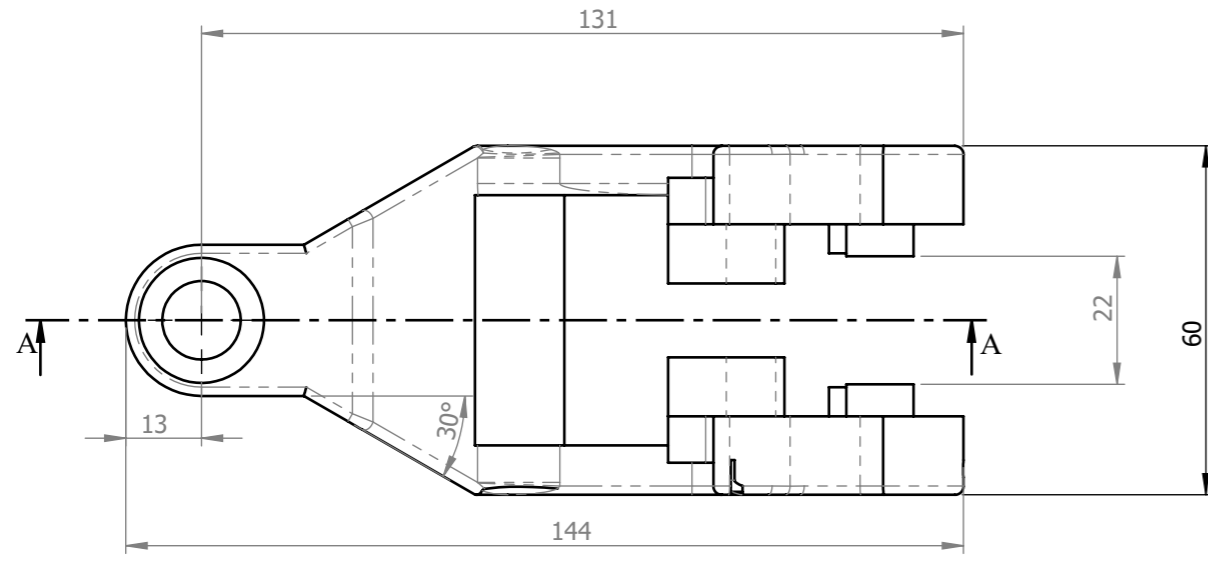

TOP VIEW

NOTE3: ALL UNSPECIFIED FILLETS R2
 NOTE2: Remove All sharp Edges.
 NOTE1: Unspecified tolerances is according to ISO 2768M.

REV	DATE	NAME	SIGN	BY	DATE	BY	DATE
				REV. CHECKED		REV. APPROVED	
SKETCH	1405/02/02	J.Motedayen		TITLE: VALVE SSSY. 3"-5000 PSI			
DRAWN	1405/02/03	J.Motedayen		M.E.S.C NO: ----			
CHECKED	1405/02/04	J.Motedayen		PART NO: ----			
APPROVED	1405/02/08	MR.SHEBANI		SHEET: 1 OF 9			
				DWG NO: SH-P01.177			