

PART NO.	PART NAME	QTY	DIMENSION	MATERIAL	SUR.H	CORE.H	WEIGH	REMARKS
1	BODY	1	AS SHOWN	AISI 4140	22 HRC			DIN 1.7225

6.3/3.2/1.6/  
▽(▽,▽)

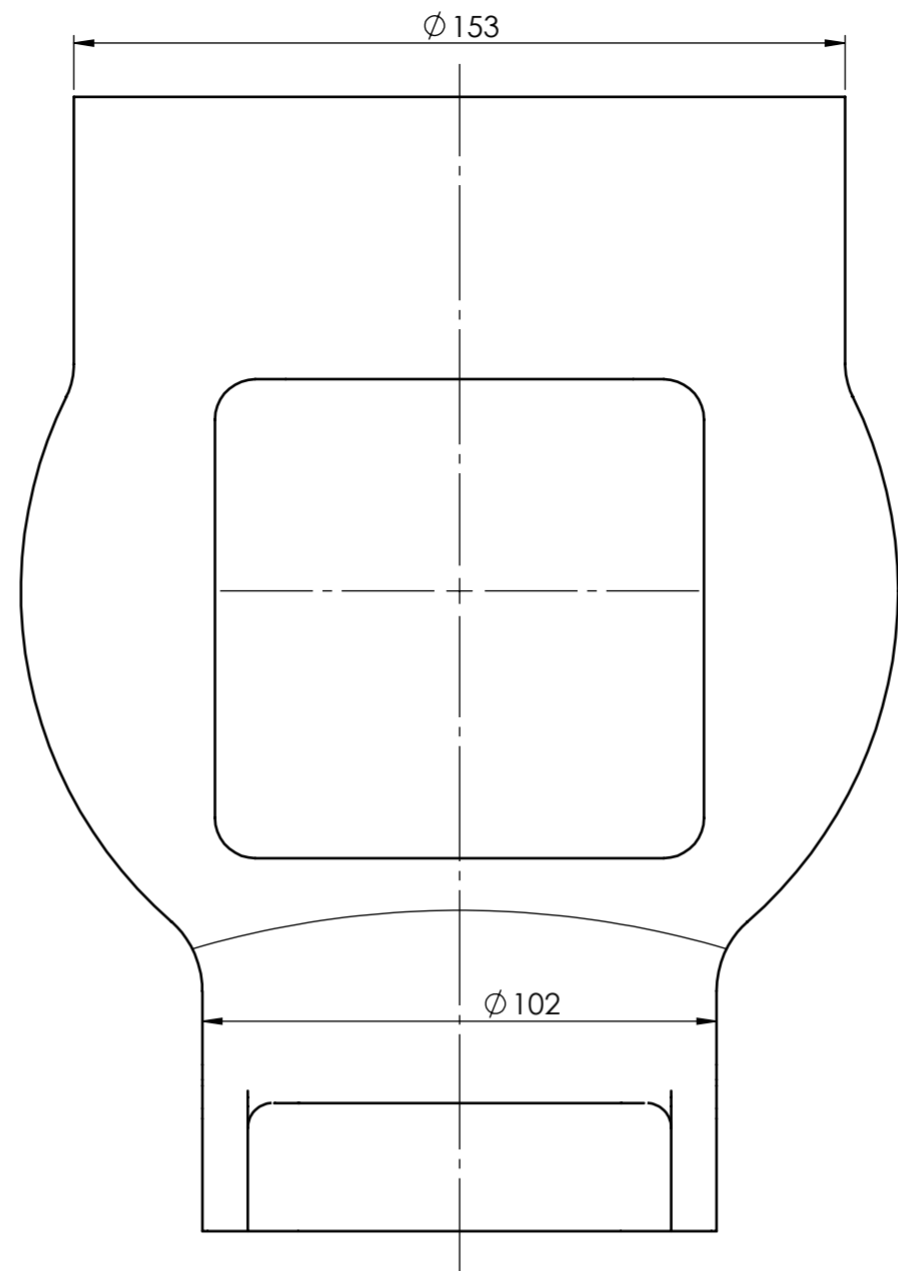

SECTION A-A

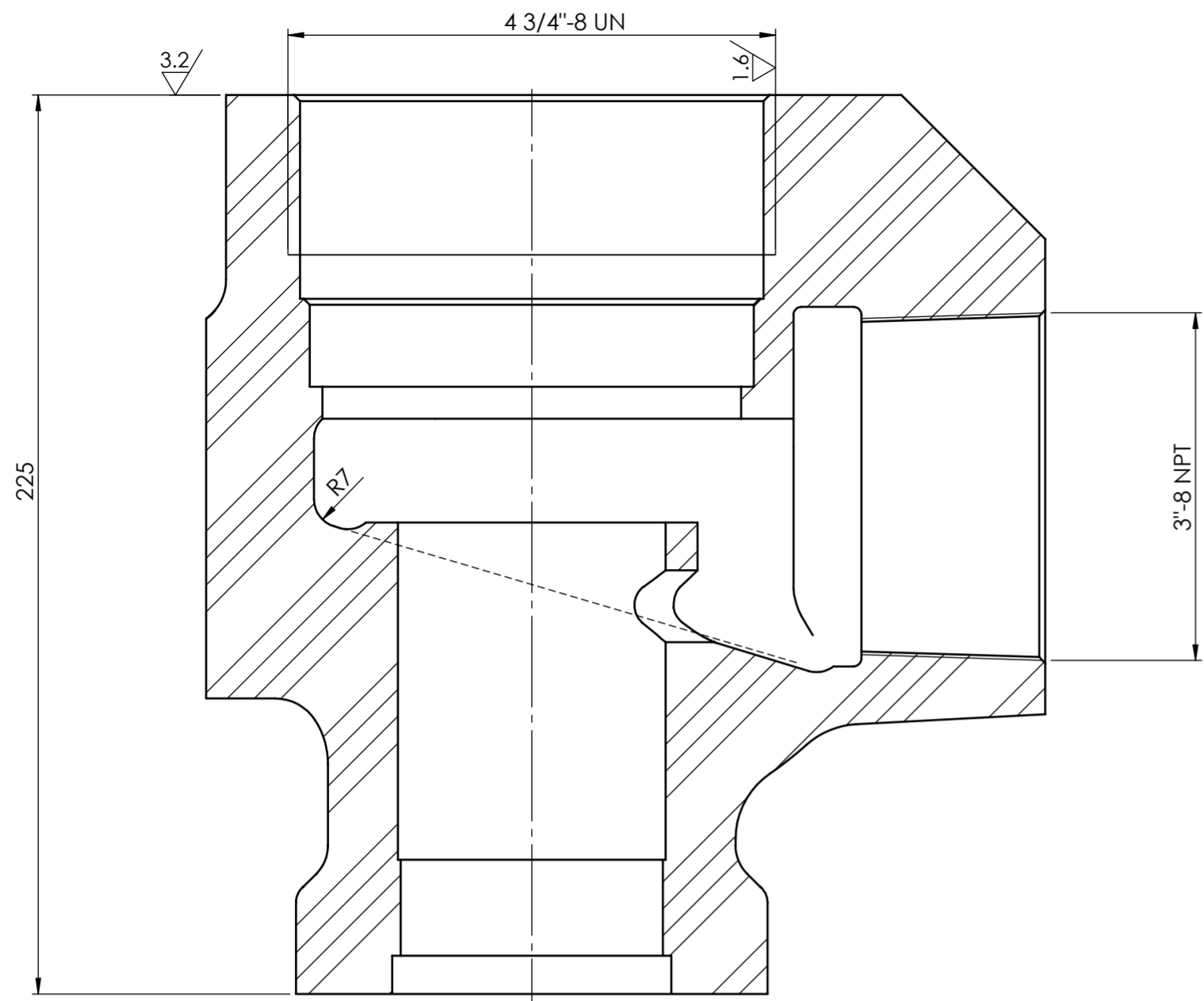
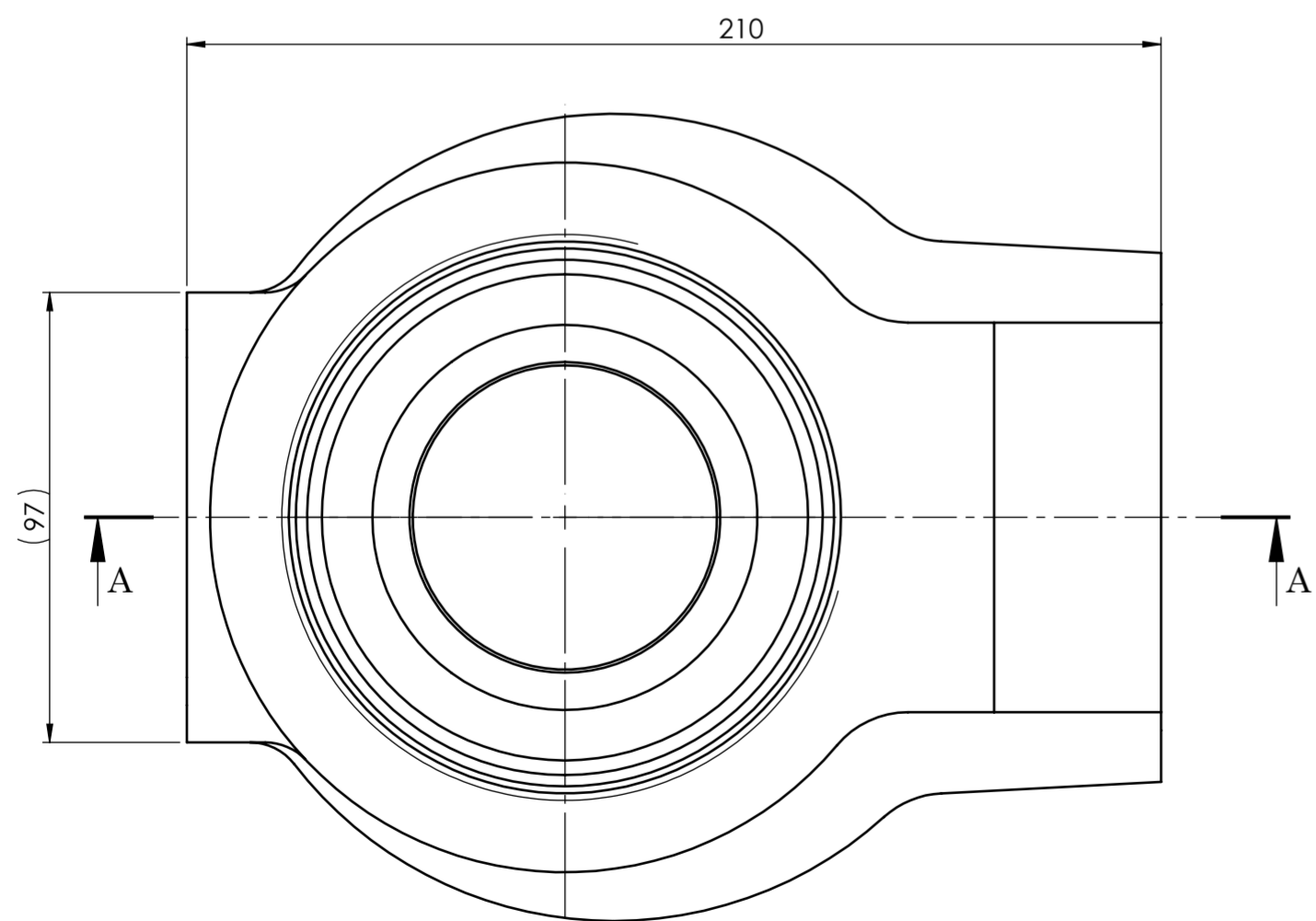

PART #1

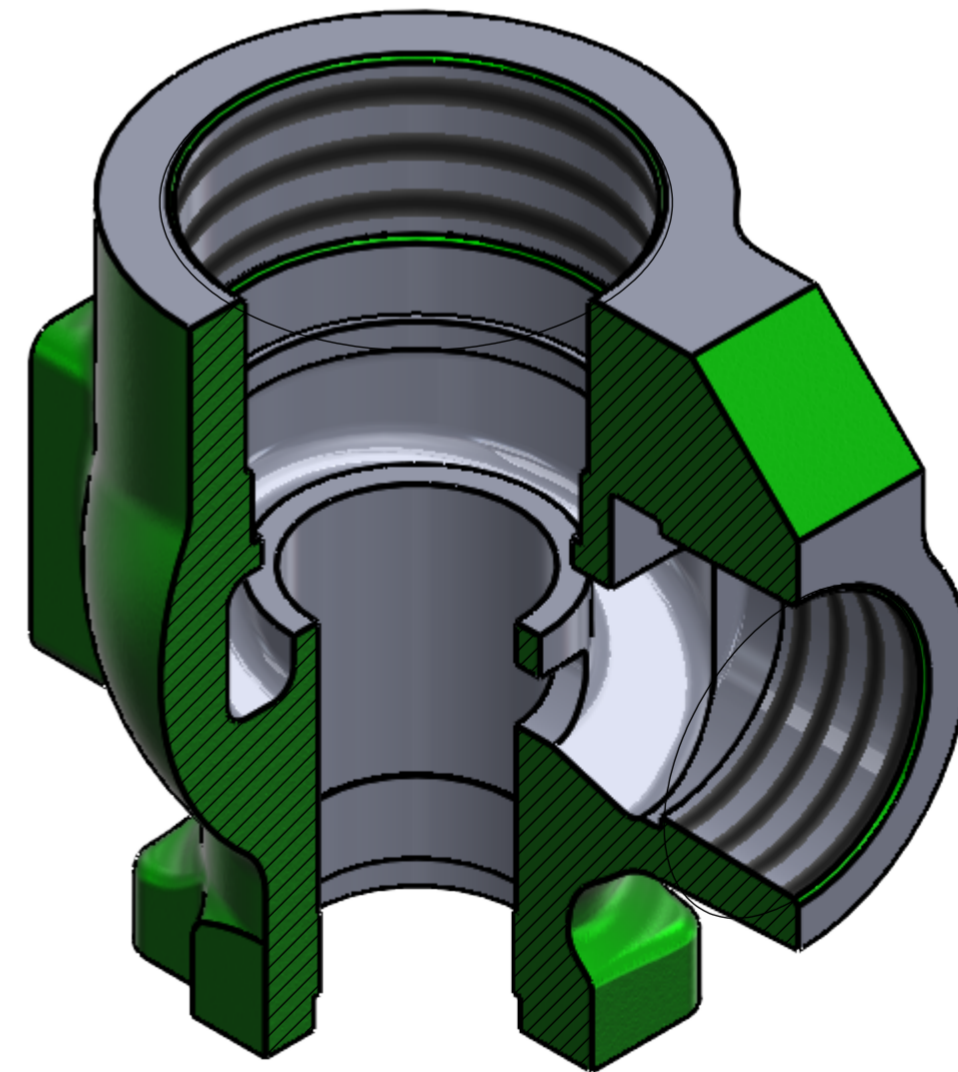

NOTE4 : MT TEST 100%  
 NOTE3 : WORKING PERSSURE 5000 PSI -TEST PRESSURE 7500PSI  
 NOTE2: Remove All sharp Edges.  
 NOTE1: Unspecified tolerances is according to DIN 7168 -m.

REV	DATE	NAME	SIGN	SCALE	TITLE
REV	DATE	NAME	SIGN	SCALE	TITLE
SKETCH	05/02/20	J.Motedayen		1:4	VALVE ASSY 3"-1500-5000 PS
DRAWN	05/02/20	J.Motedayen			M.E.S.E NO: ----
CHECKED	05/02/20	J.Motedayen			PART NO:
APPROVED	05/02/20	SHEYBANI		SIZE *** A2	SHEET: 2 OF 9
				DWG NO:	SH-P01.177